

WedgeRock RSDR PRODUCT SHEET

700150 Rev-03

MECHANICAL FAIL-SAFE OPERATOR FOR EMERGENCY SHUT DOWN APPLICATIONS

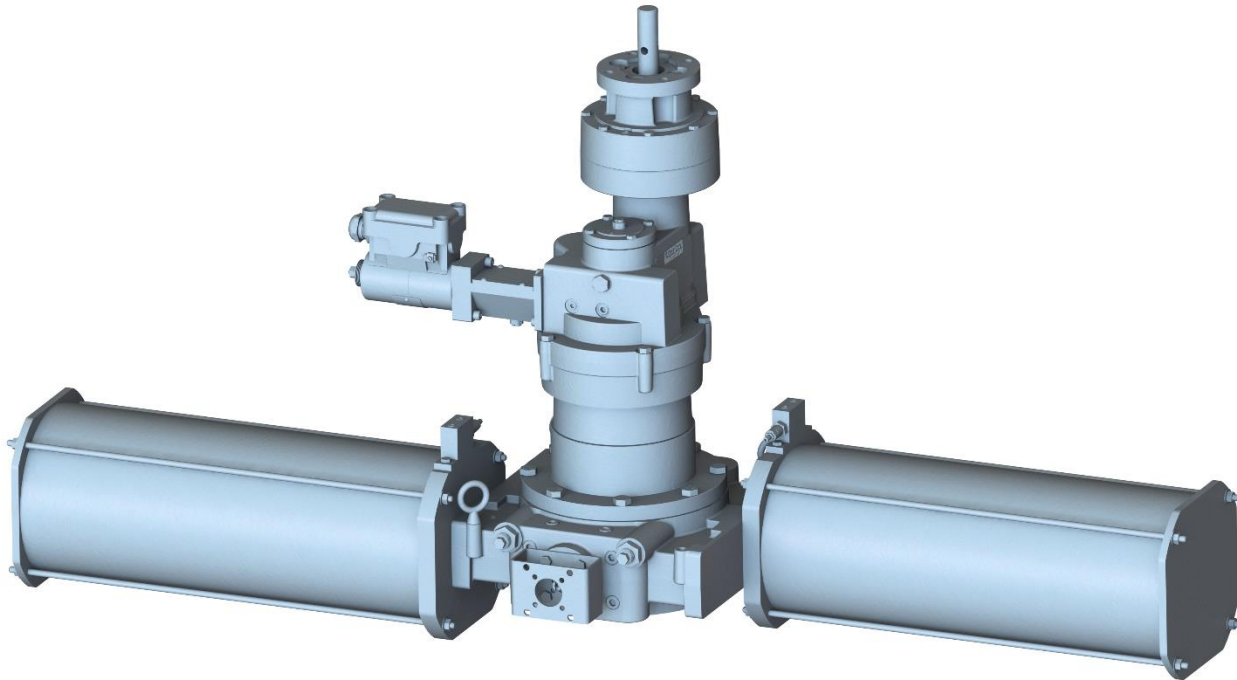

Features, Options & Configurability

- | | |
|--|--|
| <ul style="list-style-type: none"> • High efficiency gear train • Self-Locking • Mechanical stops for quarter turn rotation, $\pm 5^\circ$ adjustment at each stop • 90% filled, Greased for life, no maintenance • Elastomer seals at all ingress points, designed and tested to IP68 • Input shaft projection Parallel or Perpendicular to output • Adjustable fail stroke time • Namur mounting for indicator giving absolute valve position • Input lockout • Available Certifications: <ul style="list-style-type: none"> ○ Buy America Compliant ○ ATEX Compliant ○ SIL 3 Capable | <ul style="list-style-type: none"> • Modular design for quarter-turn applications accommodates: <ul style="list-style-type: none"> ○ Fail-Clockwise ○ Fail-Counterclockwise • Release Signal Options: <ul style="list-style-type: none"> ○ Electric ○ Hi-Lo Pressure Pilot • Capable of Partial Stroke testing • Operate with: <ul style="list-style-type: none"> ○ Electric valve actuator ○ Handwheel • Risers and Adaptors • Temperature range and materials configured per application • Machined for direct mount <ul style="list-style-type: none"> ○ Standard Flanges to MSS SP101 & ISO 5211 ○ Infinite Custom Bolt Pattern Options |
|--|--|

PURPOSE ENGINEERED - QUALITY MANUFACTURED - PERFORMANCE TESTED

The information in this document is subject to change without notice. Updated documents can be requested or obtained from our website.

WedgeRock RSDR

GENERAL OVERVIEW

MANUAL AND MOTORIZED OPERATION							
MODEL	MAX BORE W/ SQUARE KEY PER ANSI B17.1	MAX BORE W/ RECTANGULAR KEY PER ANSI B17.1	MAX CIRCUMSCRIBED DIAMETER OF DRIVE FEATURE	MAX STEM ENGAGEMENT	STANDARD FLANGE	FLANGE RANGE	
	<i>IN</i> <i>(MM)</i>	<i>IN</i> <i>(MM)</i>	<i>IN</i> <i>(MM)</i>	<i>IN</i> <i>(MM)</i>		MIN	MAX
RSDR4	1.50 <i>(38)</i>	1.50 <i>(38)</i>	1.90 <i>(48)</i>	2.85 <i>(72)</i>	F/FA10	F/FA07	F/FA12
RSDR5	2.00 <i>(51)</i>	2.00 <i>(51)</i>	2.50 <i>(64)</i>	3.00 <i>(76)</i>	F/FA12	F/FA10	F/FA14
RSDR6	2.38 <i>(60)</i>	2.50 <i>(64)</i>	3.00 <i>(76)</i>	3.25 <i>(83)</i>	F/FA14	F/FA12	F/FA16
RSDR7	3.00 <i>(76)</i>	3.25 <i>(83)</i>	3.77 <i>(96)</i>	4.00 <i>(102)</i>	F/FA16	F/FA14	F16/FA19
RSDR8	3.75 <i>(95)</i>	4.00 <i>(102)</i>	4.77 <i>(121)</i>	5.00 <i>(127)</i>	F/FA25	F/FA16	F/FA25
RSDR9	4.50 <i>(114)</i>	4.75 <i>(121)</i>	5.64 <i>(143)</i>	5.25 <i>(133)</i>	F/FA30	F25/FA19	F/FA30
RSDR10	4.50 <i>(114)</i>	4.75 <i>(121)</i>	5.60 <i>(142)</i>	5.75 <i>(146)</i>	F/FA30	F/FA25	F/FA35
RSDR12	6.75 <i>(171)</i>	7.00 <i>(178)</i>	8.50 <i>(216)</i>	8.50 <i>(216)</i>	F/FA35	F/FA25	F/FA40
RSDR14	8.25 <i>(210)</i>	8.75 <i>(222)</i>	10.26 <i>(261)</i>	10.50 <i>(267)</i>	F/FA48	F/FA35	F/FA48
RSDR18	10.00 <i>(254)</i>	11.00 <i>(279)</i>	12.75 <i>(324)</i>	13.00 <i>(330)</i>	F/FA60	F/FA40	F/FA60
RSDR24	11.00 <i>(279)</i>	12.00 <i>(305)</i>	14.00 <i>(356)</i>	15.00 <i>(381)</i>	F/FA60	F/FA48	32" OD <i>(813mm)</i>
RSDR36	12.50 <i>(318)</i>	13.00 <i>(330)</i>	15.00 <i>(381)</i>	18.00 <i>(457)</i>	As Required	F/FA60	44" OD <i>(1118mm)</i>

Larger frame sizes available if required. Contact WedgeRock for more information.

WedgeRock RSDR

ENVELOPE DIMENSIONS

RSDR ENVELOPE DIMENSIONS AND WEIGHT									
MODEL	A	B	C	D	E	F	G	H	WEIGHT
	IN (MM)	IN (MM)	IN (MM)	IN (MM)	IN (MM)	IN (MM)	IN (MM)	IN (MM)	LBS (KG)
RSDR4 + RP4 + RSR5	28.9 (734)	6.5 (166)	3.4 (87)	4.1 (103)	18.2 (462)	2.6 (65)	3.8 (95)	1.1 (29)	182 (83)
RSDR5 + RP5 + RSR5	38.5 (978)	8.7 (221)	4.6 (116)	5.4 (137)	21.1 (536)	2.6 (65)	3.8 (95)	1.5 (38)	224 (102)
RSDR6 + RP6 + RSR5	48.1 (1,222)	10.9 (276)	5.7 (144)	6.8 (171)	22.3 (566)	2.6 (65)	3.8 (95)	1.9 (48)	365 (165)
RSDR7 + RP7 + RP5 + RSR5	58.2 (1,477)	13.1 (334)	6.9 (175)	8.2 (207)	23.1 (586)	2.6 (65)	3.8 (95)	2.3 (58)	473 (214)
RSDR8 + RP8 + RP6 + RSR5	64.2 (1,630)	14.5 (368)	7.6 (193)	9.0 (229)	24.6 (625)	2.6 (65)	3.8 (95)	2.5 (63)	712 (323)
RSDR8 + RP8 + RSR6	64.2 (1,630)	14.5 (368)	7.6 (193)	9.0 (229)	27.6 (701)	2.6 (65)	3.8 (95)	2.5 (63)	756 (343)
RSDR9 + RP9 + RP6 + RSR5	85.6 (2,173)	19.3 (491)	10.1 (257)	12.0 (305)	28.3 (720)	2.6 (65)	3.8 (95)	3.3 (85)	1023 (464)
RSDR9 + RP9 + RSR6	85.6 (2,173)	19.3 (491)	10.1 (257)	12.0 (305)	31.3 (796)	2.6 (65)	3.8 (95)	3.3 (85)	1067 (484)
RSDR10 + RP10 + RP8 + RP6 + RSR5	96.3 (2,445)	21.8 (552)	11.4 (289)	13.5 (343)	37.4 (950)	2.6 (65)	3.8 (95)	3.8 (95)	1824 (827)
RSDR10 + RP10 + RP8 + RSR6	96.3 (2,445)	21.8 (552)	11.4 (289)	13.5 (343)	37.0 (941)	2.6 (65)	4.3 (108)	3.8 (95)	1864 (845)
RSDR12 + RP12 + RP8 + RP6 + RSR5	144.4 (3,667)	32.6 (829)	17.1 (433)	20.3 (514)	41.7 (1,060)	2.6 (65)	3.8 (95)	5.6 (143)	2233 (1,013)
RSDR12 + RP12 + RP8 + RSR6	144.4 (3,667)	32.6 (829)	17.1 (433)	20.3 (514)	41.4 (1,051)	2.6 (65)	4.3 (108)	5.6 (143)	2277 (1,033)
RSDR14 + RP14 + RP10 + RP8 + RSR5	144.4 (3,667)	32.6 (829)	17.1 (433)	20.3 (514)	45.7 (1,160)	2.6 (65)	3.8 (95)	5.6 (143)	3916 (1,776)
RSDR14 + RP14 + RP10 + RSR6	144.4 (3,667)	32.6 (829)	17.1 (433)	20.3 (514)	44.3 (1,125)	2.6 (65)	4.3 (108)	5.6 (143)	3919 (1,778)
RSDR18 + RP18 + RP12 + RP8 + RSR6	167.6 (4,257)	37.9 (962)	19.8 (503)	23.5 (597)	53.8 (1,367)	2.6 (65)	4.3 (108)	6.5 (166)	8702 (3,947)
RSDR18 + RP18 + RP12 + RSR8	167.6 (4,257)	37.9 (962)	19.8 (503)	23.5 (597)	54.3 (1,380)	3.0 (76)	5.0 (127)	6.5 (166)	8743 (3,966)
RSDR24 + RP24 + RP14 + RP8 + RSR6	192.5 (4,890)	43.5 (1,105)	22.8 (578)	27.0 (686)	58.4 (1,483)	2.6 (65)	4.3 (108)	7.5 (191)	10494 (4,760)
RSDR24 + RP24 + RP14 + RSR8	192.5 (4,890)	43.5 (1,105)	22.8 (578)	27.0 (686)	58.9 (1,496)	3.0 (76)	5.0 (127)	7.5 (191)	10535 (4,779)
RSDR36 + RP36 + RP18 + RP10 + RSR8	256.7 (6,519)	58.0 (1,473)	30.3 (770)	36.0 (914)	73.8 (1,873)	3.0 (76)	5.0 (127)	10.0 (254)	17351 (7,870)

Dimensions represent most common configurations. Other dimensional configurations possible.

Values subject to change with design updates.

Weight may vary with final configuration.

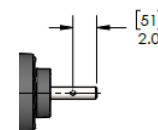
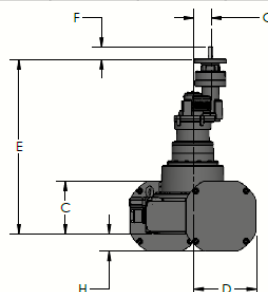
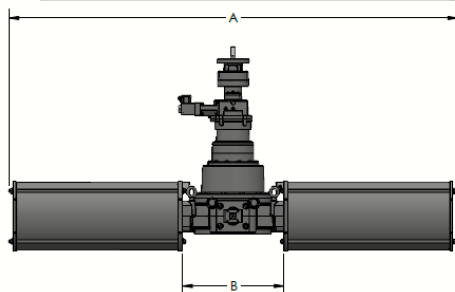

Dimension to cross hole for manually operated input

WedgeRock RP SERIES

AUXILIARY PLANETARY GEAR RATIOS

RSR SERIES PLANETARY REDUCTION GEAR

MODEL	INPUT SHAFT DIAMETER (KEY PER ANSI B17.1)	MIN STANDARD INPUT FLANGE	MAX STANDARD INPUT FLANGE
	IN (MM)		
RSR5	1.00 / 1.50 (25.4 / 38.1)	F/FA10	F/FA16
RSR6	1.00 / 1.50 (25.4 / 38.1)	F/FA14	F/FA16
RSR8	1.50 / 2.00 (38.1 / 50.8)	F/FA16	F/FA25

COMMON RATIOS FOR RP5 & RP6

RATIO ¹ [MOST COMMON]	2.50	[2.6]	2.71	2.78	2.85	[3.00]	3.18	[3.29]	3.40	3.67	4.00	[4.20]	4.43	[5.00]	5.80	[6.33]	[9.00]
MECHANICAL ADVANTAGE ²	2.4	[2.5]	2.6	2.7	2.8	[2.9]	3.1	[3.2]	3.3	3.6	3.9	[4.1]	4.3	[4.9]	5.6	[6.1]	[8.7]

COMMON RATIOS FOR RP8-RP24

RATIO ¹ [MOST COMMON]	[2.5]	2.60	2.71	2.78 [^]	2.85	[3.00]	3.18	3.29 [^]	3.40	3.67	[4.00]	4.20 [^]	4.43	[5.00]	5.80 [^]	6.33 ^{^^}	9.00 ^{^^^}
MECHANICAL ADVANTAGE ²	[2.4]	2.5	2.6	2.7	2.8	[2.9]	3.1	3.2	3.3	3.6	[3.9]	4.1	4.3	[4.9]	5.6	6.1	8.7

COMMON RATIOS FOR RP36

RATIO ¹ [MOST COMMON]	2.44	2.63	2.86	3.17	3.60	4.25	[5.33]	6.20	[^] Catalog torque rating to be reduced by 20% using this ratio ^{^^} Catalog torque rating to be reduced by 40% using this ratio ^{^^^} Catalog torque rating to be reduced by 60% using this ratio								
MECHANICAL ADVANTAGE ²	2.3	2.5	2.7	3.0	3.4	4.0	[5.1]	5.9									

COMMON RSR5 & RSR6 RATIOS

RATIO ¹ [MOST COMMON]	2.81	[2.93]	3.05	3.13	3.21	[3.38]	3.58	[3.7]	3.83	4.13	4.50	[4.73]	4.98	[5.63]	6.53	[7.12]	[10.13]
MECHANICAL ADVANTAGE ²	2.5	[2.6]	2.7	2.8	2.8	[3]	3.2	[3.3]	3.4	3.6	4.0	[4.2]	4.4	[5]	5.8	[6.3]	[8.9]

COMMON RSR8 RATIOS

RATIO ¹ [MOST COMMON]	[2.81]	2.93	3.05	3.13	3.21	[3.38]	3.58	3.70	3.83	4.13	[4.5]	4.73	4.98	[5.63]	6.53	7.12	10.13
MECHANICAL ADVANTAGE ²	[2.5]	2.6	2.7	2.8	2.8	[3]	3.2	3.3	3.4	3.6	[4]	4.2	4.4	[5]	5.8	6.3	8.9

1) Additional ratios available upon request.

2) Mechanical advantage can fall short of published value by 10% until gearbox has worn in. Wear in should occur within 10 cycles.

WedgeRock HANDWHEELS

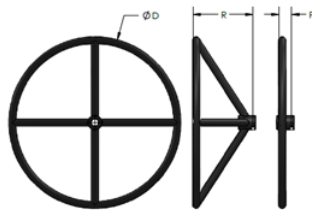

D	R	F
IN	IN	IN
(MM)	(MM)	(MM)
6	5.25	1.75
(152)	(133)	(44)
12	5.25	1.75
(305)	(133)	(44)
18	6.25	1.75
(457)	(159)	(44)
24	8.38	1.75
(610)	(213)	(44)
30	10.00	1.75
(762)	(254)	(44)
36	9.63	1.75
(914)	(244)	(44)
42	10.13	1.75
(1,067)	(257)	(44)

HANDWHEEL SIZE CHART

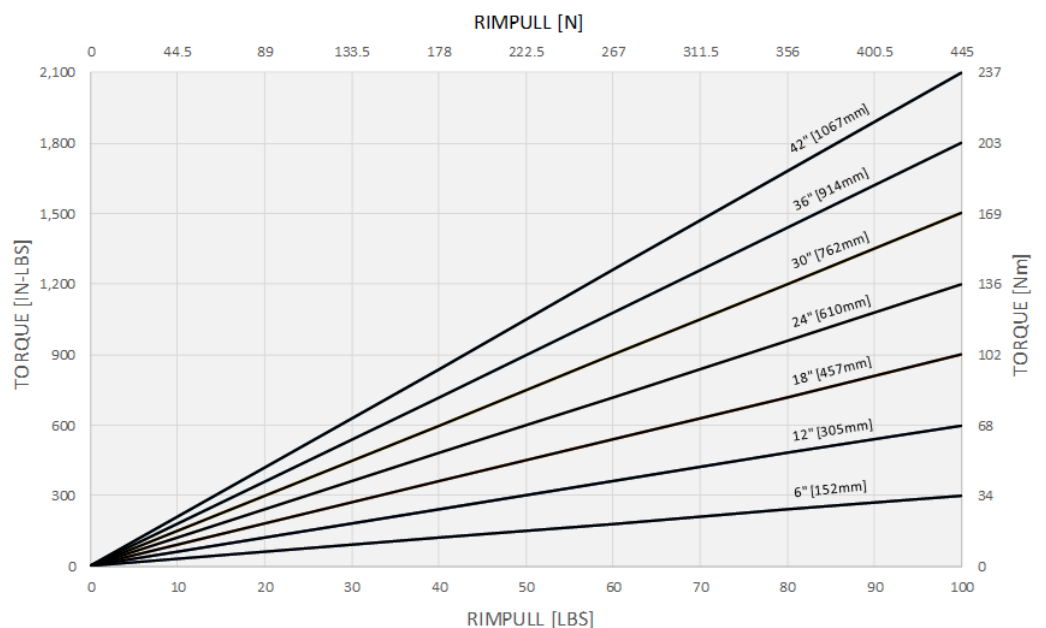

OUTPUT TORQUE RATING FOR QUARTER TURN, FAIL-SAFE APPLICATIONS

Frame Size	Frame Rating In-Lbs/(Nm)	Spring Can	RSDR Output Torque In-Lbs/(Nm)						Planetary Gear Configuration	Gear Ratio						Mechanical Advantage						RSDR Input Torque for Max Rating In-Lbs/(Nm)																														
			Fail (Spring)			Max Operated				1.00	2.60	3.00	4.20	5.00	6.33	9.00	+/- 10%																																			
			Start	Run	End	Start	Run	End									2.0	5.0	5.7	8	10	12	17	2531	1004	870	621	522	412	290																						
RSDR4	5,000 (565)	60	1,500 (169)	1,395 (158)	1,290 (146)	3,710 (419)	3,605 (407)	3,500 (395)	RP4-2.6 RSR5	2.9	7.6	8.8	12	15	19	26	2.0	5.0	5.7	8	10	12	17	(286)	(113)	(98)	(70)	(59)	(47)	(33)																						
		80	2,000 (226)	1,860 (210)	1,720 (194)	3,280 (371)	3,140 (353)	3,000 (339)																							RP5-5.0 RSR5	5.6	15	17	24	28	36	51	3.8	9.6	11	15	18	23	33	(297)	(118)	(102)	(73)	(61)	(48)	(34)
		100	2,500 (282)	2,325 (263)	2,150 (243)	2,850 (322)	2,675 (302)	2,500 (282)																																												
60	3,000 (339)	2,790 (315)	2,580 (292)	7,420 (838)	7,210 (815)	7,000 (791)	RP7-5.0/ RP5-3.0/ RSR5	17	44	51	71	84	107	152	11	28	32	45	54	68	96	(407)	(164)	(139)	(99)	839	663	466																								
80	4,000 (452)	3,720 (420)	3,440 (389)	6,560 (741)	6,280 (710)	6,000 (678)																							RP8-5.0/ RP6-3.0/ RSR5	28	73	84	118	141	178	253	18	46	54	75	89	113	161	(460)	(182)	(158)	(113)	(95)	(75)	(53)		
100	5,000 (565)	4,650 (525)	4,300 (486)	5,700 (644)	5,350 (605)	5,000 (565)																																													RP9-5.0/ RP6-9.0/ RSR5	51
60	8,400 (949)	7,812 (883)	7,224 (816)	20,776 (2,348)	20,188 (2,281)	19,600 (2,215)	RP10-5.0/ RP8-6.3/ RP5-2.6/ RSR5	93	241	278	389	463	586	833	59	148	171	240	285	361	513	(432)	(171)	(149)	(106)	(89)	(70)	(50)																								
80	11,200 (1,266)	10,416 (1,177)	9,632 (1,098)	18,368 (2,075)	17,584 (1,987)	16,800 (1,898)																							RP10-5.0/ RP8-2.6/ RSR6	15	38	44	61	73	93	132	9.6	24	28	39	46	59	84	(23488)	9313	8071	5765	4843	3825	2690		
100	14,000 (1,582)	13,020 (1,471)	12,040 (1,360)	15,960 (1,803)	14,980 (1,693)	14,000 (1,582)																																													RP12-5.0/ RP6-6.33/ RSR5	178
60	13,500 (1,525)	12,555 (1,419)	11,610 (1,312)	33,390 (3,773)	32,445 (3,666)	31,500 (3,559)	RP12-5.0/ RP8-5.0/ RSR6	28	73	84	118	141	178	253	18	46	54	75	89	113	161	(2453)	(973)	(843)	(602)	(506)	(400)	(281)																								
80	18,000 (2,041)	16,740 (1,894)	15,480 (1,749)	29,520 (3,336)	28,260 (3,193)	27,000 (3,051)																							RP14-5.0/ RP12-6.3/ RP8-9.0/ RSR5	320	833	961	1346	1602	2028	2884	204	513	592	829	987	1250	1777	(416)	(165)	(143)	(102)	(86)	(68)	(48)		
100	22,500 (2,542)	20,925 (2,364)	19,350 (2,186)	25,650 (2,898)	24,075 (2,720)	22,500 (2,542)																																													RP14-5.0/ RP12-9.0/ RSR6	51
60	22,500 (2,542)	20,925 (2,364)	19,350 (2,186)	55,650 (6,288)	54,075 (6,110)	52,500 (5,932)	RP18-5.0/ RP12-5.0/ RSR6	84	219	253	354	422	534	759	54	135	156	218	260	329	468	(25183)	9985	8654	6181	5192	4101	2885																								
80	30,000 (3,390)	30,001 (3,153)	30,002 (2,915)	30,003 (5,559)	30,004 (5,322)	30,005 (5,085)																							RP18-5.0/ RP12-5.0/ RSR8	28	73	84	118	141	178	253	18	45	52	73	87	110	156	(8537)	(3385)	(2934)	(2095)	(1760)	(1390)	(978)		
100	37,500 (4,237)	34,875 (3,941)	32,250 (3,644)	42,750 (4,831)	40,125 (4,534)	37,500 (4,237)																																													RP24-5.0/ RP14-5.0/ RSR6	141
60	40,500 (4,576)	37,665 (4,256)	34,830 (3,936)	100,170 (11,319)	97,335 (10,998)	94,500 (10,678)	RP24-5.0/ RP18-9.0/ RSR6	51	132	152	213	253	320	456	32	81	94	131	156	197	281	(69952)	27737	24038	17170	14423	11393	8013																								
80	40,500 (4,576)	50,220 (5,675)	46,440 (5,247)	88,560 (10,007)	84,780 (9,580)	81,000 (9,153)																							RP36-5.0/ RP18-5.0/ RSR8	141	366	422	591	703	890	1266	89	225	260	364	433	549	780	(50365)	19970	17308	12363	10385	8203	5769		
100	67,500 (7,627)	62,775 (7,093)	58,050 (6,559)	76,950 (8,695)	72,225 (8,161)	67,500 (7,627)																																													RP36-5.0/ RP18-5.0/ RSR8	141
60	67,500 (7,627)	62,775 (7,093)	58,050 (6,559)	166,950 (18,864)	162,225 (18,331)	157,500 (17,797)	RP36-5.0/ RP18-5.0/ RSR8	141	366	422	591	703	890	1266	89	225	260	364	433	549	780	(5691)	(2257)	(1956)	(1397)	(1173)	(927)	(652)																								
80	90,000 (10,169)	83,700 (9,458)	77,400 (8,746)	147,600 (16,678)	141,300 (15,966)	135,000 (15,254)																							RP36-5.0/ RP18-5.0/ RSR8	141	366	422	591	703	890	1266	89	225	260	364	433	549	780	(5691)	(2257)	(1956)	(1397)	(1173)	(927)	(652)		
100	112,500 (12,712)	104,625 (11,822)	96,750 (10,932)	128,250 (14,492)	120,375 (13,602)	112,500 (12,712)																																													RP36-5.0/ RP18-5.0/ RSR8	141
60	120,000 (13,559)	111,600 (12,610)	103,200 (11,661)	296,800 (33,537)	288,400 (32,588)	280,000 (31,638)	RP36-5.0/ RP18-5.0/ RSR8	141	366	422	591	703	890	1266	89	225	260	364	433	549	780	(5691)	(2257)	(1956)	(1397)	(1173)	(927)	(652)																								
80	160,000 (18,079)	148,800 (16,814)	137,600 (15,548)	262,400 (29,650)	251,200 (28,384)	240,000 (27,119)																							RP36-5.0/ RP18-5.0/ RSR8	141	366	422	591	703	890	1266	89	225	260	364	433	549	780	(5691)	(2257)	(1956)	(1397)	(1173)	(927)	(652)		
100	200,000 (22,599)	186,000 (21,017)	172,000 (19,435)	228,000 (25,763)	214,000 (24,181)	200,000 (22,599)																																													RP36-5.0/ RP18-5.0/ RSR8	141
60	225,000 (25,424)	209,250 (23,644)	193,500 (21,864)	556,500 (62,881)	540,750 (61,102)	525,000 (59,322)	RP36-5.0/ RP18-5.0/ RSR8	141	366	422	591	703	890	1266	89	225	260	364	433	549	780	(5691)	(2257)	(1956)	(1397)	(1173)	(927)	(652)																								
80	300,000 (33,898)	279,000 (31,525)	258,000 (29,153)	492,000 (55,593)	471,000 (53,220)	450,000 (50,847)																							RP36-5.0/ RP18-5.0/ RSR8	141	366	422	591	703	890	1266	89	225	260	364	433	549	780	(5691)	(2257)	(1956)	(1397)	(1173)	(927)	(652)		
100	375,000 (42,373)	348,750 (39,407)	322,500 (36,441)	427,500 (48,305)	401,250 (45,339)	375,000 (42,373)																																													RP36-5.0/ RP18-5.0/ RSR8	141
60	405,000 (45,763)	376,650 (42,559)	348,300 (39,356)	1,001,700 (113,186)	973,350 (109,983)	945,000 (106,780)	RP36-5.0/ RP18-5.0/ RSR8	141	366	422	591	703	890	1266	89	225	260	364	433	549	780	(5691)	(2257)	(1956)	(1397)	(1173)	(927)	(652)																								
80	540,000 (61,0																																																			

Torque VS Valve Position of RS and Valve

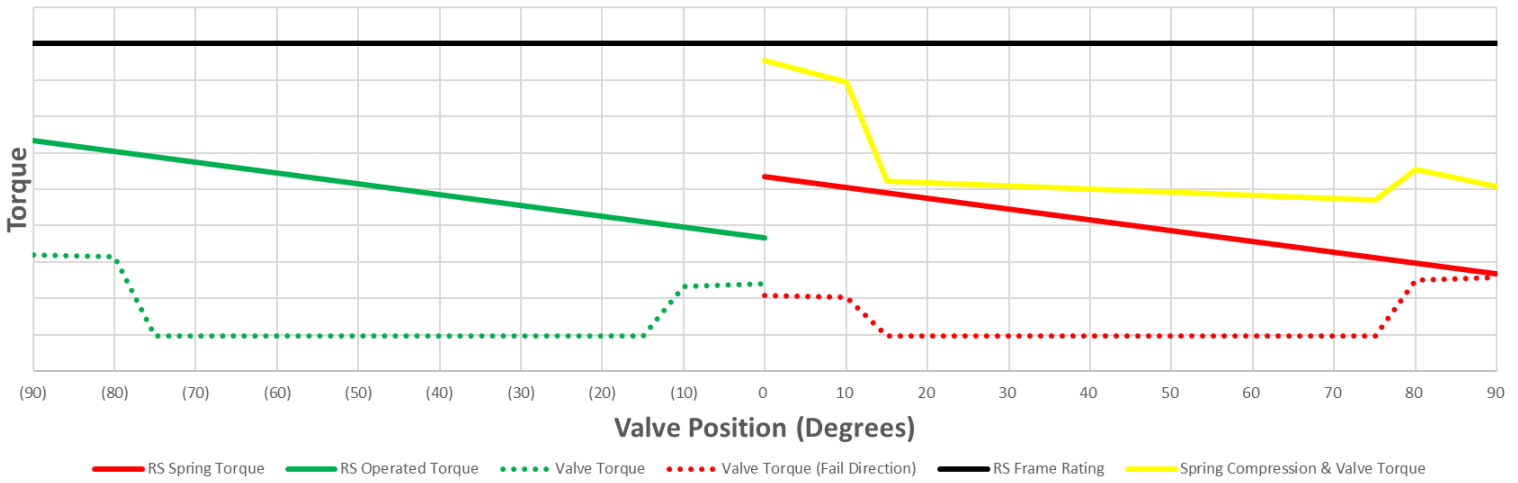

Position	Valve Torque	Choose One		Safety Factor	Frame Sizing Check
		RS Fail -Close	RS Fail-Open		
Start to Open				<input type="text"/>	
Run to Open				<input type="text"/>	
End to Open				<input type="text"/>	
Start to Close				<input type="text"/>	<input type="text" value="Frame Torque"/>
Run to Close				<input type="text"/>	<input type="text"/>
End to Close				<input type="text"/>	<input type="text"/>

Useful Equations

#_{in} = Input Turns to Operate ¼ Turn
D_{hw} = Handwheel Diameter
MA = Mechanical Advantage
N = Gear Ratio
F_{rp} = Rimpull
RPM = Input RPM
T_{1/4} = Time to Operate ¼ Turn (Sec)
T_{in} = Input Torque
T_{out} = Output Torque

Input turns to operate ¼ turn

$$\#_{in} = \frac{N}{4}$$

Time to operate ¼ turn (Seconds)

$$T_{1/4} = \frac{15 \times N}{RPM}$$

Mechanical Advantage

$$MA = \frac{T_{out}}{T_{in}}$$

Required Input Torque

$$T_{in} = \frac{T_{out}}{MA}$$

Required Rimpull

$$F_{rp} = \frac{2 \times T_{in}}{D_{hw}}$$

Required Handwheel Diameter

$$D_{hw} = \frac{2 \times T_{in}}{F_{rp}}$$

Position	Indicates position of valve and RS being analyzed.
Valve Torque	Torque required by valve to operate without safety factor.
RS Fail-Close / Fail-Open	RS output torque per selected frame size. Fail(Spring) output torque filled in red boxes, Max Operated output torque filled in green boxes.
Safety Factor	Safety factor of RS capacity over valve requirement. RS Torque / Valve Torque
Frame Sizing Check	For fail-close, valve torque in the open direction added to the RS Fail output torque. For fail-open, valve torque in the close direction added to the RS fail output torque. The max torque found here can be divided by the desired input torque to find the minimum required mechanical advantage.
Frame Torque	Frame torque should always be higher than all three torques listed in the yellow boxes.

WedgeRock RSDR SERIES

TEMPERATURE AND SERVICE CONDITIONS

STANDARD COMPONENT MATERIAL SELECTION FOR SPECIFIED ENVIRONMENTS		
COMPONENT	SERVICE CONDITION	
	STANDARD TOPSIDE	OFFSHORE PLATFORM
HOUSINGS ¹	DUCTILE IRON AND CARBON STEEL	DUCTILE IRON AND CARBON STEEL
SPRING HOUSING	CARBON STEEL	CARBON STEEL
SPRING	COATED ALLOY STEEL	COATED ALLOY STEEL
INPUT SHAFT	STAINLESS STEEL	SUPER DUPLEX STAINLESS STEEL
STOPS	ALLOY STEEL	ALLOY STEEL
JAM NUT(S)	STEEL	SEALED STEEL
FASTENERS ²	GRADE 5	316SS
SEALS ³	BUNA	BUNA
LUBRICATION ⁴	GREASE	GREASE
FINISH ⁵	EPOXY PRIMER	EPOXY PRIMER
1-Models RS12 and larger may use carbon steel fabrications in place of ductile iron.		
2-Standard fasteners for application. Option to use Grade 5, 316SS, B7(M), L7(M), or other materials per project specification. Grade 5 is zinc plated.		
3-Standard seals for application unless otherwise specified. Refer to temperature service condition table.		
4-Lubrication per temperature condition. Refer to temperature service condition table.		
5-Standard finish unless otherwise specified. Standard epoxy 7-10 mils dft.		

TEMPERATURE SERVICE CONDITIONS		
SERVICE CONDITION	MIN OPERATING TEMP	MAX OPERATING TEMP
	°F (°C)	°F (°C)
STANDARD SERVICE	-20 (-29)	140 (60)
Wider operating temperature ranges are available. Consult with factory.		

WedgeRock Mechanical Spring Return (RSDR) Operation

All Electric Spring Return Solution

Patent Pending

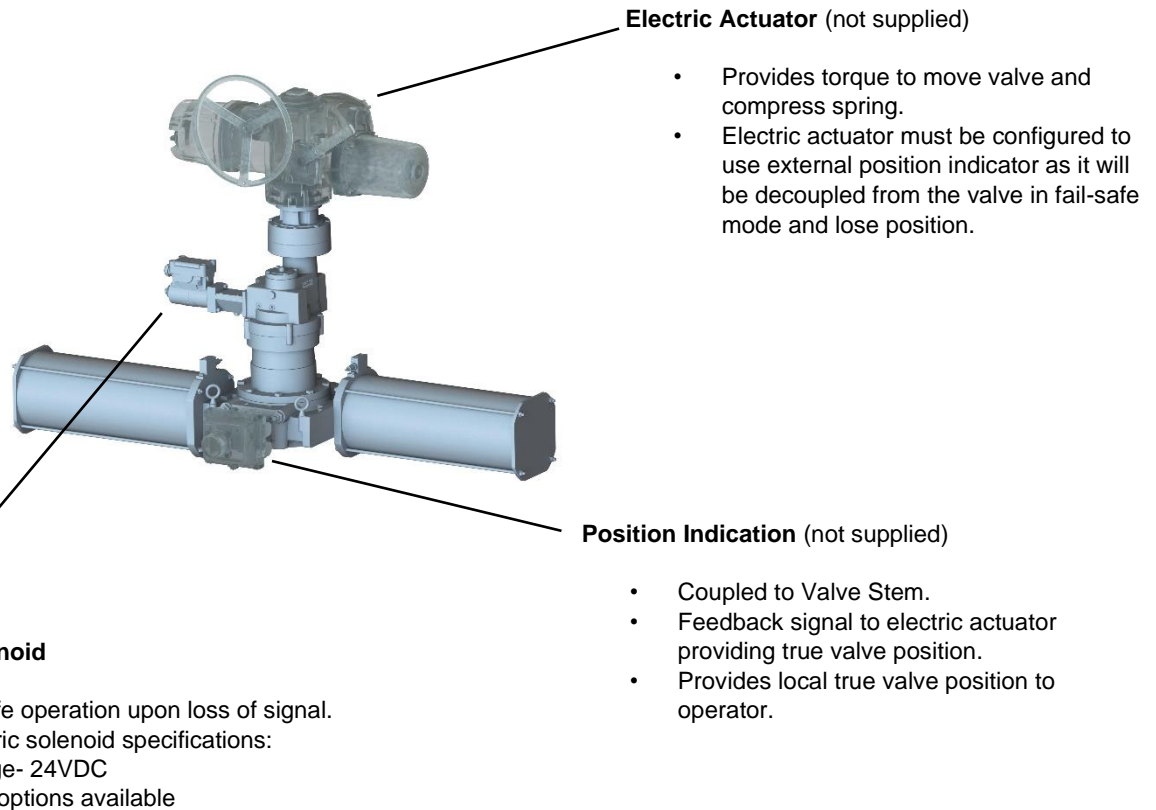

Example Modes of Operation

(Methods of operation may depend on hardware used or criteria for system failure.)

Example 1

Standard Operation

- Valve is operated in one direction only by the electric actuator.
(Operation compresses the spring.)
- Valve is operated in the opposing direction by the spring when solenoid signal is removed.

Fail-Safe Operation

- Upon loss of signal to solenoid, the spring is released to a fail-safe position.
- When signal returns, normal operation can resume.

Example 2

Standard Operation

- Valve is operated both open and shut by the electric actuator.
(Operation compresses and decompresses the spring.)

Fail-Safe Operation

- Upon loss of signal to solenoid, the spring releases to a fail-safe position.
- When power returns, the electric actuator can either recognize position from a position transmitter or reset by operating to the fail position, then the signal is restored to the solenoid re-engaging the spring. (Operation of the actuator while the solenoid has lost signal will not change the valve position from the fail state.)

WedgeRock Mechanical Spring Return (RS) Operation

All Manual Spring Return Solution

Patent Pending

Manual Input

- Handwheel provided per application for operation.

Spring Release Line Pressure Operated (LPO)

- Starts fail-safe operation when pressure limit setting is exceeded.
 - High pressure limit setting
 - Low pressure limit setting
- Hi/Lo pressure settings from 10 to 10,000 psi.

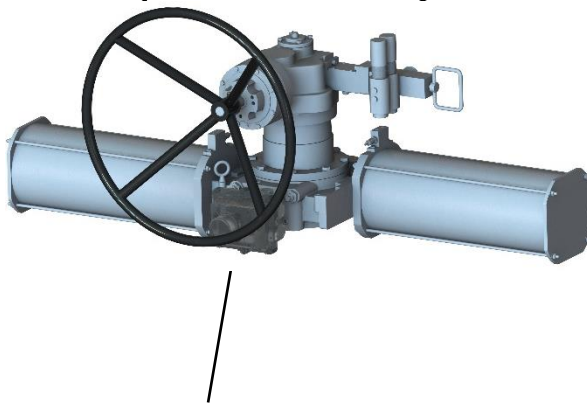

Position Indication

- Coupled to Valve Stem.
- Provides local true valve position to operator.

Example Modes of Operation

(Methods of operation may depend on specific application.)

Example 1

Standard Operation

- Valve is operated in one direction only using handwheel. (Operation compresses the spring.)
- Operating in opposing direction
 - Valve is operated in the opposing direction by the spring when manual override button depressed on LPO.
 - Operate handwheel in opposing direction decompressing spring.

Fail-Safe Operation

- Upon pressure signal falling or exceeding set limits in the LPO, the spring is released to a fail-safe position.

LPP Reset

- When pressure returns within acceptable limits, a handle is pulled and the LPO is disengaged from the RS. The handwheel is then able to operate the RS and position the valve as needed.
- Optionally, if for example a pipeline has no pressure and the low limit is set to some value, the LPP can be configured to pull the handle to disengage the LPO from the RS before the pipeline pressure returns within set limits. The handwheel is then able to operate the RS and position the valve as needed. Once pressure returns within limits, the LPO will be able to release the spring of the RS and operate to a fail-safe position should the pressure exceed the set limits.

ABOUT WEDGEROCK

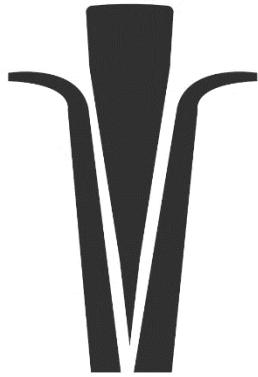

The WedgeRock name and logo symbolize the elegance of a simple and effective design and the grit, focus, and determination required to make things happen – the work required to get big things moving. Pragmatism and hard work are central to our culture and reflected in everything we do.

Don't let our dirty hands and old school approach fool you. WedgeRock brings industry leading innovation to your engineered projects in standard lead times.

With a focused approach, WedgeRock provides solutions for the most demanding torque and thrust application. Whether you need to operate valves thousands of meters below the ocean surface, or a purpose designed gear operator for your valve line, give us a call or send an email to get the partnership started.

OUR MISSION

WedgeRock provides performance engineered actuation solutions for demanding applications.

