

# DGAB Series Quarter Turn Gearbox

Heavy-duty part-turn gearboxes suitable for ball, butterfly, plug valves serving oil & gas, water, power, chemical and demanding industrial application.

## DGAB24 – DGAB36 – DGAB41 – DGAB47 – DGAB68

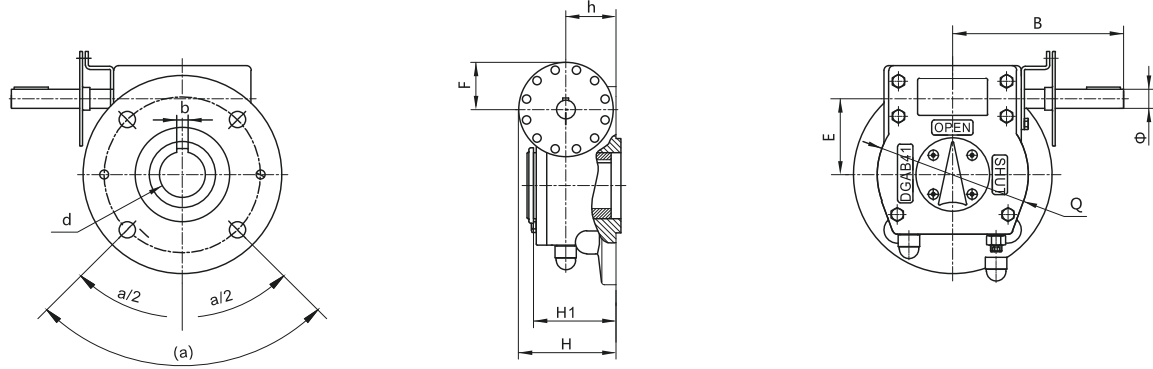

## DGAB68B – DGAB178 – DGAB275

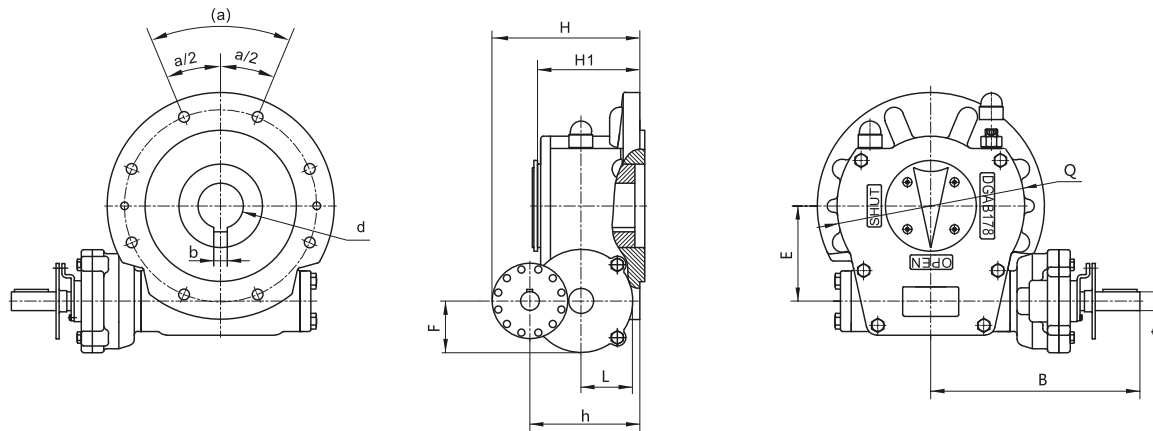

## DGAB323 – DGAB525 – DGAB664/B - DGAB1086/B/C

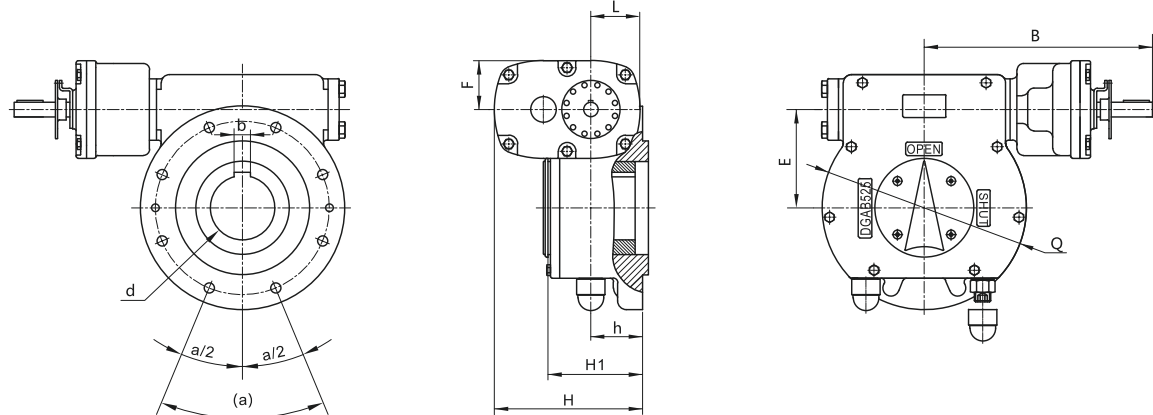

- Output torque up to 55.000 Nm
- IP67 and IP68 available as option
- Easy to install and operate, maintenance free
- Ductile Iron housing, maritized duty option available on request
- Accessories available on request: Limit Switch, Locking Device, Chainwheels and Interlock

Model	Flange Type / External diameter	Ratio	ISO 5211 Output flange - Performance data					Outline dimensions									
			Input torque	Maximum output torque	Mechanical Advnatage +10%	Maximum stem shaft bore d	Maximum stem Height H1	E	Φ	B	F	H	h	Q	L	Handwheel diameter	Weight
			Nm	Nm		mm	mm	mm	mm	mm	mm	mm	mm	mm	mm	mm	mm
DGAB24	F07/90 F10/125	24:1	56	400	7,2	28	61	44,5	15	144	30	71	31	91	-	250	4
DGAB36	F10/125 F12/150	36:1	68	750	11	35	73	61,5	18	154	31	83	41	121	-	320	6
DGAB41	F10/175 F12/175 F14/175 F16/210	41:1	102	1300	12,7	45	82	80,5	20	181	35	92	48	160	-	360	11
DGAB47	F12/175 F14/175 F16/210	47:1	125	1800	14,4	50	88	89,5	20	181	37,5	98	54	178	-	460	12
DGAB68	F14/210 F16/210 F20/255 F25/300	68:1	158	3000	19	70	99	126	25	200	50	109,5	59	245	-	600	24
DGAB68B	F14/210 F16/210 F20/255 F25/300	136:1	100	3800	38	70	99	126	25	263	50	154	104	245	47,5	460	28
DGAB178	F16/210 F25/300	178:1	135	6500	52	75	117	126	25	296	68	178,5	128,5	248	68	460	36
DGAB275	F25/300 F30/350	275:1	110	8500	77	95	137	138	25	318	92,5	209	159	264	92,5	600	63
DGAB323	F25/350 F30/350	323:1	123	11000	89	100	136	154,5	25	346	68,5	206,5	69	300	69	600	73
DGAB525	F25/350 F30/350	538:1	114	17000	149	110	148	169	25	379	84	241	76	350	84	600	89
DGAB664	F30/415 F35/415	698:1	145	28000	193	130	178	230	25	417	90	272	94	468	90	600	146
DGAB664B	F30/415 F35/415	1302:1	120	38000	316,7	130	178	230	30	454	150	374	94	468	139	600	175
DGAB1086	F35/475 F40/475 F48/560	1086:1	155	42000	271	160	201	276,5	30	472	116	342	106	559	116	600	229
DGAB1086B	F35/475 F40/475 F48/560	1258:1	142	48000	338	160	201	276,5	30	472	116	342	106	559	116	600	229
DGAB1086C	F35/475 F40/475 F48/560	1701:1	136	58000	427	160	201	276,5	30	525	162	410	106	559	151	600	260

# DGABD Series Quarter Turn Gearbox for Automation

Heavy-duty part-turn gearboxes suitable for ball, butterfly, plug valves serving oil & gas, water, power, chemical and demanding industrial application.

- Output torque up to 42.000 Nm
- IP67 and IP68 available as option
- Easy to install and operate, maintenance free
- Ductile Iron housing
- Atex conformity available on request

## DGAB24D – DGAB68D

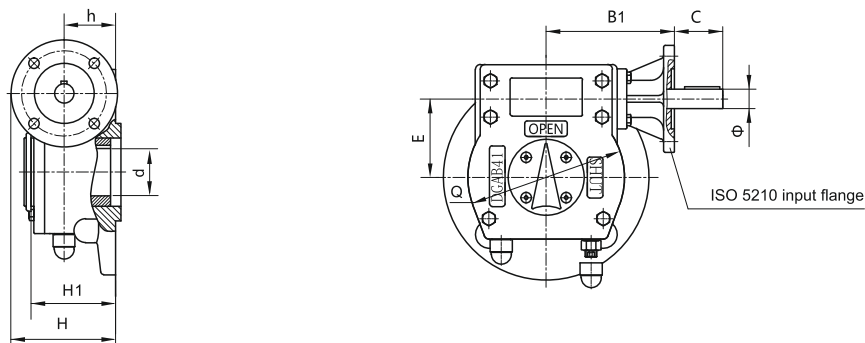

## DGAB68BD – DGAB275D

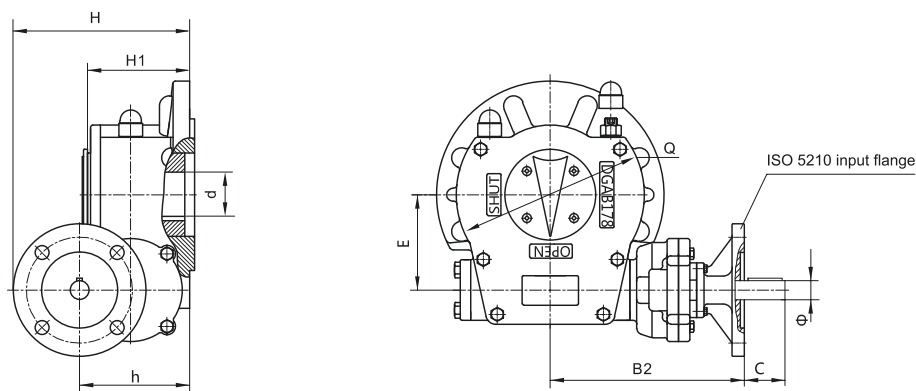

## DGAB323D – DGAB1086BD

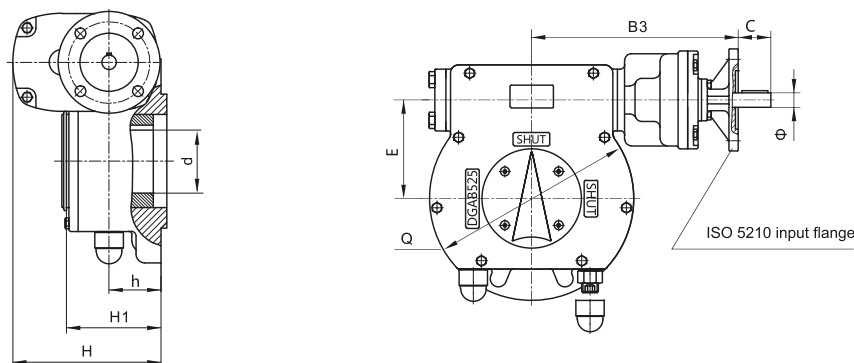

Model	ISO 5211 Output flange - Performance data								Input flange size ISO 5210					Outline dimensions			
	Flange Type/ External diameter	Ratio	Input torque	Maximum output torque	Mechanical Advnatage +10%	Maximum stem shaft bore d	Maximum stem Height H1	E	Flange type	Ø	C	B1	B2	B3	H	h	Q
			Nm	Nm		mm	mm										
DGAB24D	F07/90 F10/125	24:1	45	320	7,2	28	61	44,5	F10	15	38	106			93,5	31	91
DGAB36D	F10/125 F12/150	36:1	55	600	11	35	73	61,5	F10	18	37,5	116			103,5	41	121
DGAB41D	F10/175 F12/175 F14/175 F16/210	41:1	87	1100	12,7	45	82	80,5	F10 F14	20	35,5	145,5			110,5	48	160
DGAB47D	F12/175 F14/175 F16/210	47:1	100	1450	14,4	50	88	89,5	F10 F14	20	35,5	145,5			116,5 141,5	54	178
DGAB68D	F14/210 F16/210 F20/255 F25/300	68:1 136:1	140 78	2660	19 34	70	99	126	F14 F10	25 43	45	168		220	136,5 166,5	59 104	245
DGAB178D	F16/210 F25/300	51:1 178:1	355 103	5500	15,5 53	75	117	126	F14 F16 F10 F14	30 25	45 43	195 253			148,5 166 191 216	61 128,5	248
DGAB275D	F25/300 F30/350	55:1 165:1 275:1	487 163 95	7500	15,4 46 77	95	137	138	F16 F14 F10 F14	35 25 25	53 43	239		275	174 246,5 221,5 246,5	69 159 159	264
DGAB323D	F25/350 F30/350	51:1 153:1 323:1	685 234 109	9800	14,3 42 90	100	136	154,5	F16 F25 F14 F10 F14	35 30 25	53 45 43	237		291	174 219 225,5 202 202	69 138 69	300
DGAB525D	F25/350 F30/350	46:1 138:1 538:1	1103 375 102	15000	13,6 40 147	110	148	169	F25 F14 F16 F10 F14	45 35 25	68 45 43	237		324	226 244,5 262 241 241	76 157 76	350
DGAB664D	F30/415 F35/415	64:1 183:1 277:1 698:1	1223 440 290 117	22000	18 50 75,9 188	130	178	230	F30 F16 F14 F10 F14	50 35 35 25	75 53 43	279		392 392	269 287 272 272	94 182 182 94	468
DGAB1086D	F35/475 F40/475 F48/560	67:1 180:1 268:1 1086:1	1778 667 445 110	32000	18 48 72 392	160	201	276,5	F30 F16 F25 F16 F10 F14	55 45 35 30	98 53 53 43	339		447 447	281 331 376 331 342	106 226 226 106	559
DGAB1086BD	F35/475 F40/475 F48/560	67:1 290:1 1258:1	2328 536 124	42000	18 78 339	160	201	276,5	F35 F16 F10 F14	65 45 30	98 68 43	339		447	314 331 342	106 226 106	559

# D6 Series Quarter Turn Gearbox

Heavy-duty part-turn gearboxes suitable for ball, butterfly, plug valves serving oil & gas, water, power, chemical and demanding industrial application.

## D603 – D604D

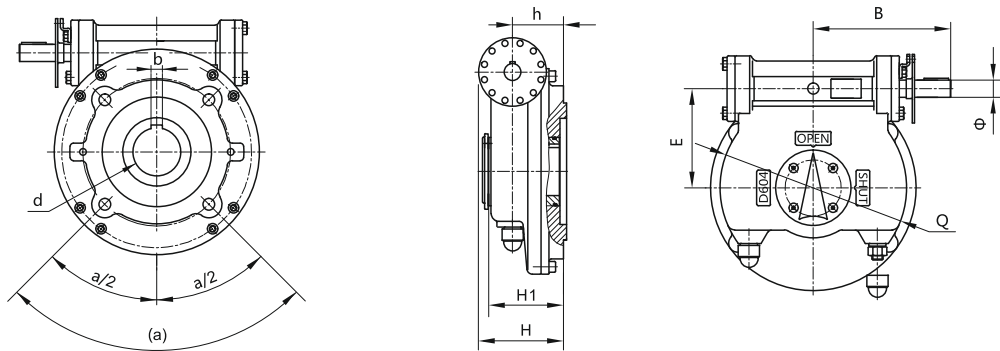

## D604 – D605 – D605 – D607A – D608

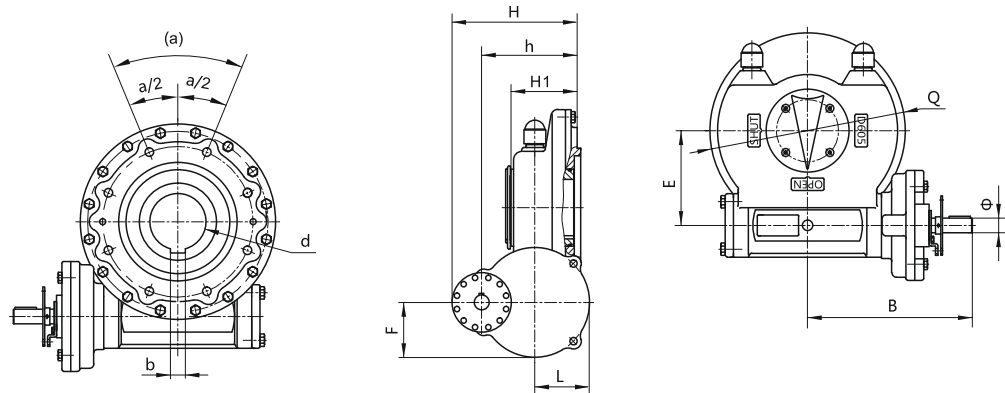

## D609 – D610 – D611 – D612 – D613

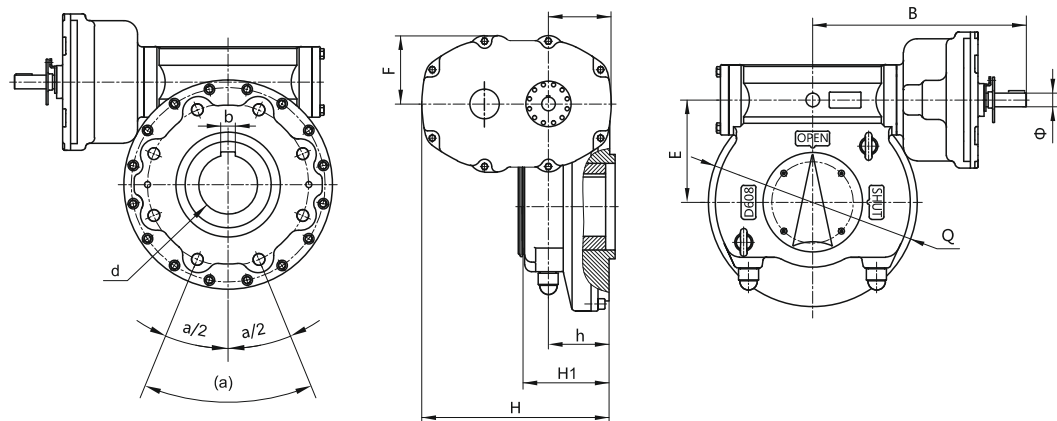

- Output torque up to 180.000 Nm
- IP67 and IP68 available as option
- Easy to install and operate, maintenance free
- Carbon Steel / Stainless / Low Temperature Carbon Steel housing
- Accessories available on request: Limit Switch, Locking Device, Chainwheels and Interlock

Model	ISO 5211 Output flangem performance data							Outline dimintions									
	Flange Type / External diameter	Ratio	Input torque	Maximum output torque	Mechanical Advnatage +10%	Maximum stem shaft bore d	Maximum stem Height H1	E	Φ	B	F	H	h	Q	L	Handwheel diameter	Weight
			Nm	Nm													
D603	F12/210 F14/210 F16/210	60:1	133	2000	15	50	86	111,5	25	177	50	108	57	214	/	460	18,3
D604A	F14/255 F16/255 F20/300 F25/300	80:1	150	3000	20	70	110	145	25	203	50	125	75	273	/	600	38
D604	F14/255 F16/255 F20/300 F25/300	160:1	114	4500	39,4	70	110	145	25	277	59	170	120	273	59	460	30
D605	F16/255 F20/300 F25/300	335:1	100	8500	85	80	112	160	25	290	92,5	212	162	304	92,5	600	54
D606	F25/350 F30/350	729:1	80	15000	188	100	137	187,5	30	377	100	291	89	358	100	600	107
D607A	F25/350 F30/350	648:1	130	22000	170	120	150	202	30	401	100	302	97	384	100	600	136
D607	F25/350 F30/350	852:1	140	30000	214	120	150	202	30	406	115	329	97	384	115	600	124
D608	F30/415 F35/415	1303:1	117	42000	359	150	184	226	30	460	150	408	128	430	139	600	198
D609	F30/475 F35/475 F40/475	1584:1	125	55000	440	170	198	254	30	509	162	444	140	491	151	600	270
D610	F35/475 F40/475	2080:1	136	78000	573	190	240	279	35	633	145	429	284	536	145	600	353
D611	F35/560 F40/560 F48/560	2662:1	135	100000	741	190	258	308	35	668	151	455	304	594	151	600	430
D612	F48/560 F60/686	2992:1	180	140000	778	240	281	380	35	690,5	192	386	336	722	192	600	680
D613	F48/560 F60/686	4036:1	172	180000	1047	280	321	450	35	755	254	458	384	828	254	600	1046

# D6D Series Quarter Turn Gearbox for Automation

Heavy-duty part-turn gearboxes suitable for ball, butterfly, plug valves serving oil & gas, water, power, chemical and demanding industrial application.

- Output torque up to 150.000 Nm
- IP67 and IP68 available as option
- Easy to install and operate, maintenance free
- Carbon Steel / Stainless / Low Temperature Carbon Steel housing
- Atex conformity available on request

## D603D – D604D

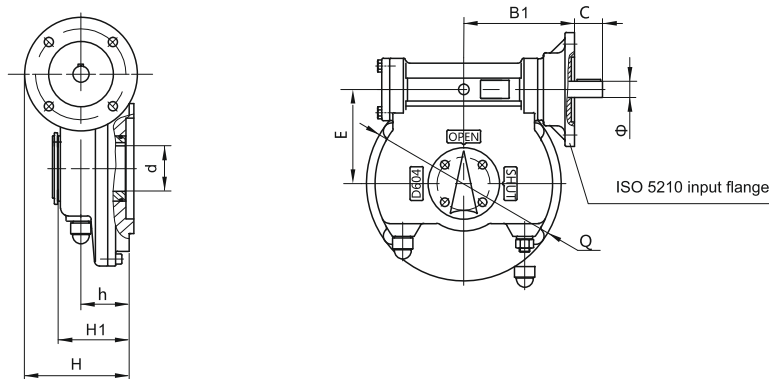

## D605D – D610D – D611D – D612D – D613D

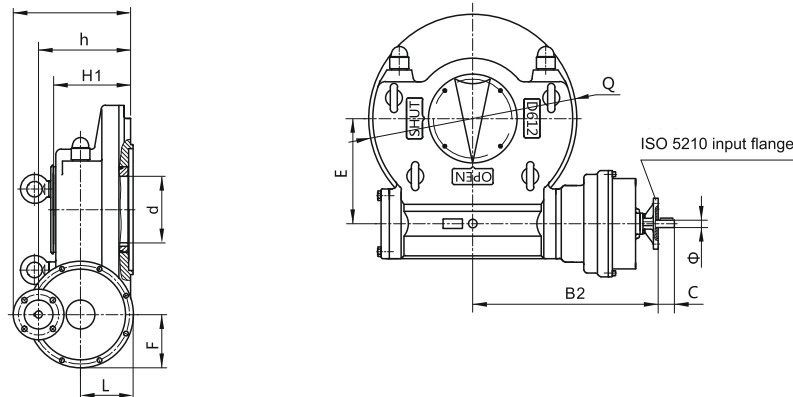

## D606D – D607D – D608D – D609D

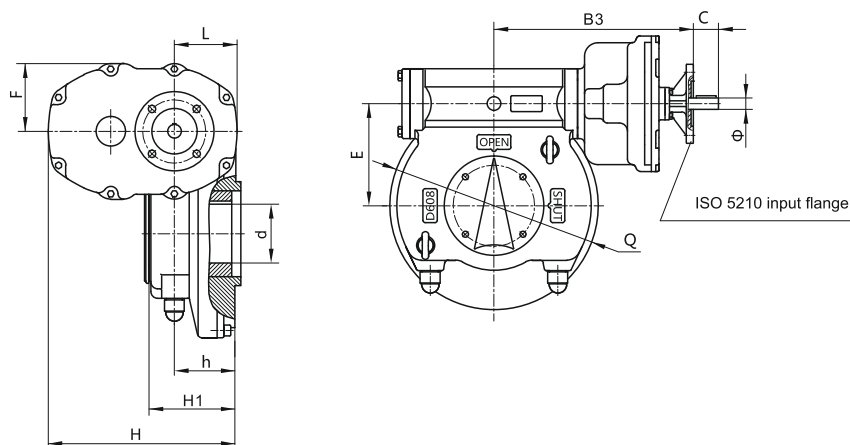

Model	ISO 5211 Output flange - Performance data								Input flange size ISO 5210					Outline dimensions			
	Flange Type/ External diameter	Ratio	Input torque Nm	Maximum output torque Nm	Mechanical Advnatage +10%	Maximum stem shaft bore d mm	Maximum stem Height H1 mm	E mm	Flange type	Ø mm	C mm	B1 mm	B2 mm	B3 mm	H mm	h mm	Q mm
D603D	F12/210 F14/210 F16/210	60:1	107	1600	15	50	86	111,5	F10 F14	25	43	162			119,5 144,5	57	214
D604D	F14/255 F16/255 F20/300 F25/300	80:1	182	3600	20	70	110	145	F14	25	43	184			162,5	75	273
		160:1	91		39,4				F10	25	43		234		182,5	120	
D605D	F14/255 F16/255 F20/300 F25/300	67:1	400	6800	17	80	112	160	F16	35	53	195			177	72	304
		201:1	139		48,9				F10 F14	25	43		247		249,5 274,5	162	
		335:1	80		85				F10	25	43		247		249,5	162	
D606D	F25/350 F30/350	63:1	741	12000	16,2	100	137	187,5	F16 F25	50	75	245			194 239	89	358
		189:1	247		48				F14	30	45		321		278,5	191	
		729:1	64		188				F10	30	43			334	291	89	
D607D	F25/350 F30/350	56:1	1704	24000	14,1	120	150	202	F30	50	75	257			272	97	384
		186:1	513		47				F16	40	60		382		317	214	
		852:1	112		214				F10 F14	30	43			363	329	97	
D608D	F30/415 F35/415	54:1	2267	33600	14,8	150	184	226	F30	65	98	300			303	128	430
		228:1	537		63				F16 F25	45	68		435		374 419	269	
		1303:1	94		359				F10 F14	30	43			417	408	128	
D609D	F30/475 F35/475 F40/475	54:1	2935	44000	15	170	198	254	F35	65	98	328			348	140	491
		252:1	629		70				F25	45	68		482,5		443	293	
		1584:1	100		440				F10 F14	30	43			465	444	140	
D610D	F35/475 F40/475	52:1	4360	62400	14,3	190	240	279	F35	70	105	360			366	158	536
		416:1	545		115				F16	45	68			528	429	158	
		2080:1	109		573				F10 F14	35	43		590		429	284	
D611D	F35/560 F40/560 F48/560	52:1	5533	80000	14,5	190	258	308	F40	80	120	380			410	172	594
		503:1	572		140				F16	45	68			563	455	172	
		2662:1	108		741				F10 F14	35	43		625		455	304	
D612D	F48/560 F60/686	64:1	6730	112000	16,6	240	281	380	F40	95	143	411			438	183	722
		316:1	1363		82				F30	50	75			586	358	183	
		2992:1	144		778				F14	35	43		648		429	336	
D613D	F48/560 F60/686	61:1	9128	144000	15,8	280	321	450	F40	110	165	476			441	204	828
		434:1	1283		112				F30	50	75			661,5	379	204	
		4036:1	138		1047				F14	35	43		712		462	384	